

MPLSv1.0 Topology :: Physical

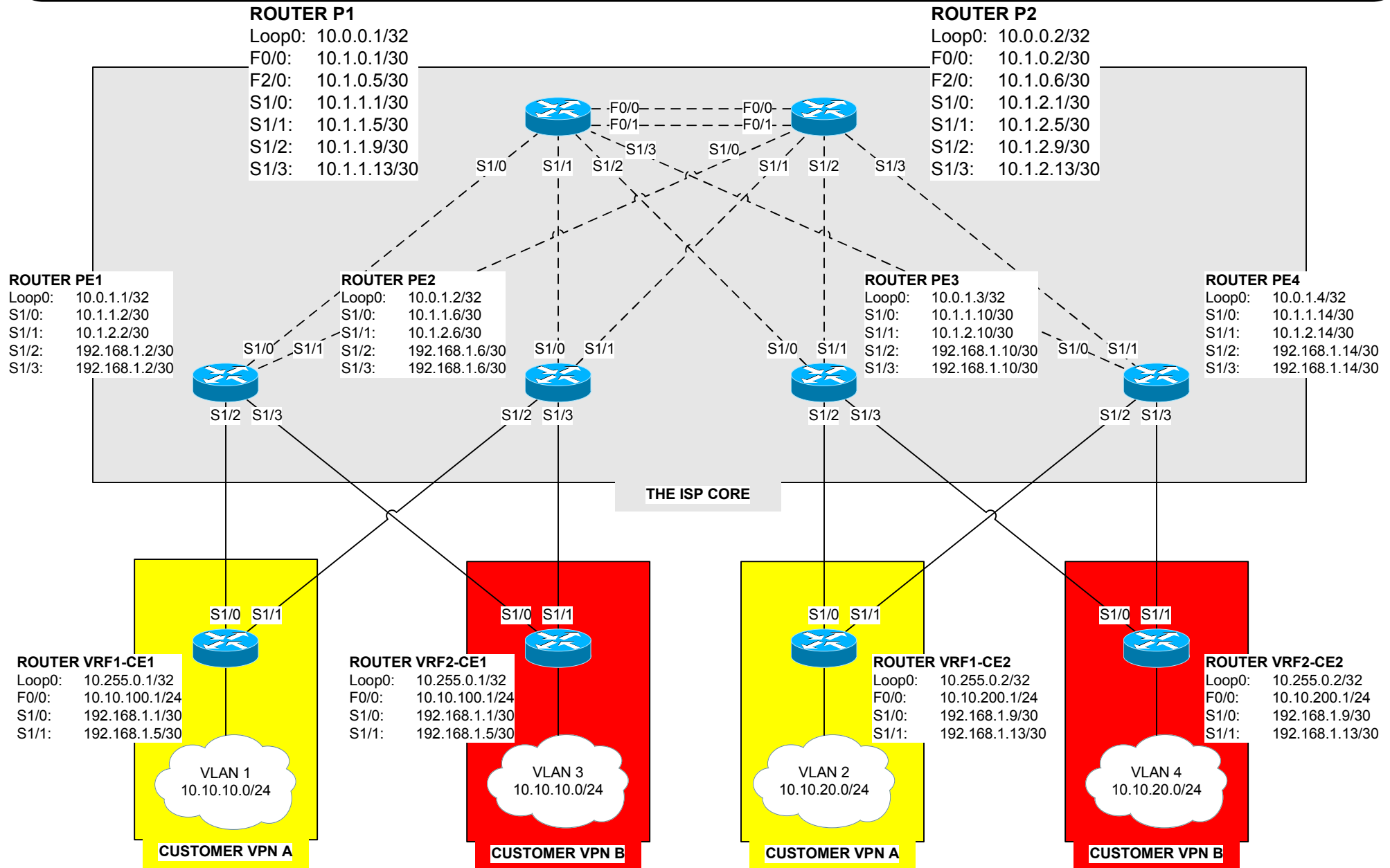

MPLSv1.0 Topology :: MPLS IGP Routing

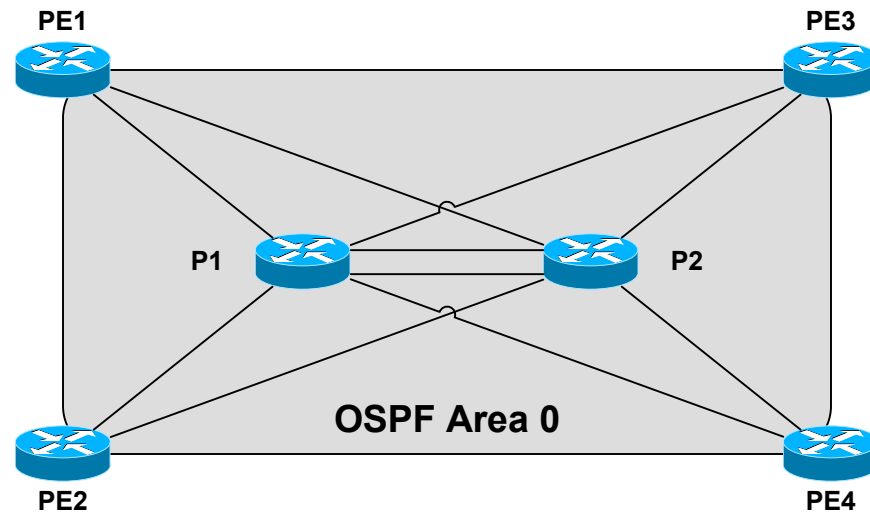

MPLSv1.0 Topology :: MPLS BGP Routing

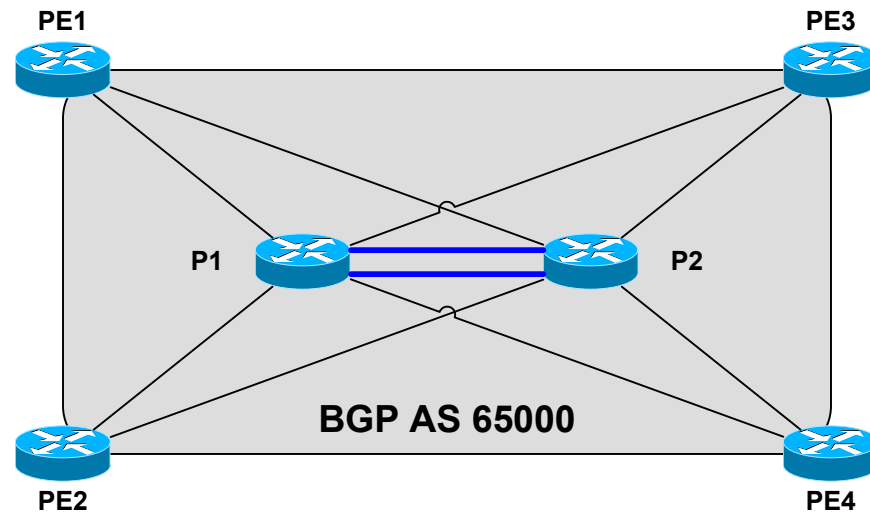

All PE routers are route-reflector clients of the P routers.
Both P routers offer separate route-reflector clusters.
The blue lines represent standard iBGP peering.
The black lines represent route-reflector iBGP peering.

MPLSv1.0 Topology :: PE-CE Routing

